





Our company

YOUR COMPANY CAN HELP
THE ENVIRONMENT
INSTALLING FILTRATION
SYSTEMS MADE BY ENERCON

Enercon was founded in 1980 to respond to the special plant requirements of a group operating in the purification and waste disposal sector. Its elastic, highly dynamic structure soon found a place in the plant technology market at domestic and international level. **Enercon** was initially set up as an engineering group whose tasks included acquiring the order, designing the plant and constructing the installation with the cooperation of outside workshops. Since 1986, **Enercon** has had its own production unit, which builds the plant in its own materials, without making use of outside companies.

Today, **Enercon** has developed a specialization in the special applications sector to offer its customers customized solutions to specific problems, with the construction of made to measure equipment and plant and prototypes. In more than thirtyfive years of operations, **Enercon**

has built up technical and technological knowledge, and has set up a company structure of the highest professional levels. **Enercon** is a point of reference for demanding customers, to whom it offers a selected turnkey supply formula which has already obtained widespread, unanimous approval.

APPLICATIONS

- Oil fog and vapour suction and filtering systems;
- Dust suction and filtering systems;
- Fume suction and filtering systems;
- industrial hydraulic systems;
- Soundproofing;
- Special applications;
- Soil treatment systems;
- Energy saving and recovery;
- Cogeneration systems;
- Assistance and maintenance services.



Oil fog and vapour suction systems



Two parts hoods on die casting machines complete with ENERORESS filters, extraction fans and expulsion chimneys - Italy

In recent years, **Enercon** has examined the problem of fume or oil fog vapour suction and purification manufacturing many plants.

Problems have been studied and solved specially in the fields of die-casting, non ferrous metal moulding and in machining (work stations).

These plants have been designed and produced with a interception system, installed on each machine (press – milling), conceived to allow an easy and non limiting efficiency of the ever more automised machines, i.e. robots.

The fog and vapour abatement filtering unit can be assembled onboard and can be of two different kinds: electrostatic or mechanic.

These filters are arranged for a self automatic washing, as an alternative it is possible to assemble a central system downstream from the interceptions ensuring simplicity, practicality and low maintenance cost. This system allows a good abatement efficiency with the plant's control and maintenance in one place.



■ Aluminum die-casting machines with hoods in two parts complete with individual ENERPRESS filters connected to centralized suction - Italy

Enercon is present in the following fields:

- Aluminium die-casting department;
- Brass hot-working;
- Detaching liquid nebulisations;
- Tools' cooling water nebulisations;
- Nebulisations of synthetic cutting oils or of gaseous oils variously polluted and from different origin;
- Pollutants of different type and origin;
- Nebulisations from work stations.



■ Die-casting machines with hoods in two parts complete with ENERPRESS filters, fans and individual chimneys for the expulsion of air purified in the atmosphere - Spain

Electrostatic filter for recycling the purified air into the working area with heat recovery



- 1** Pre filter panels coalescing;
- 2** Electrostatic filters;
- 3** Fan;
- 4** High efficiency filter for internal recirculating air;
- 5** Filters washing system;
- A** Filtered air recirculation within the production department with heat recovery (Winter);
- B** Expulsion filtered air outside the production department (Summer).

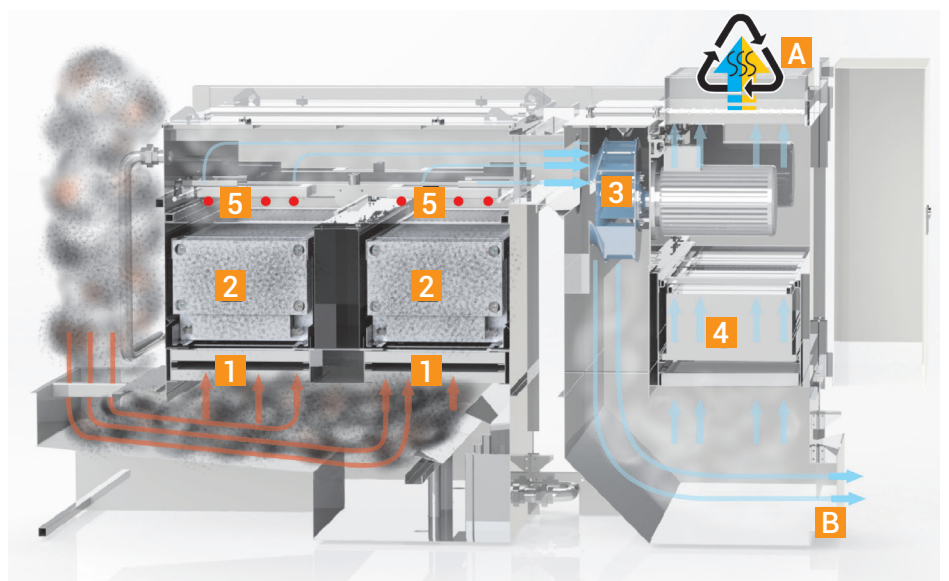



ENERPRESS filters on independent supporting structures dedicated to die casting machines with fans and expulsion chimneys. Italy



ENERPRESS filter on an independent structure with mobile washing tank beside it, dedicated to a single die-casting machine and connected to a centralized suction unit. Ukraine



Automatic cleaning system of the filter: in detail, the washing manifold, mobile by means of gearmotors and the nozzles that allow the complete washing of electrostatic cells and mechanical panels. Pollutants are collected in the tank integrated in the filter.

Hoods and filters on diecasting machines



■ Hoods on presses connected to a centralized suction and filtration system - Uzbekistan

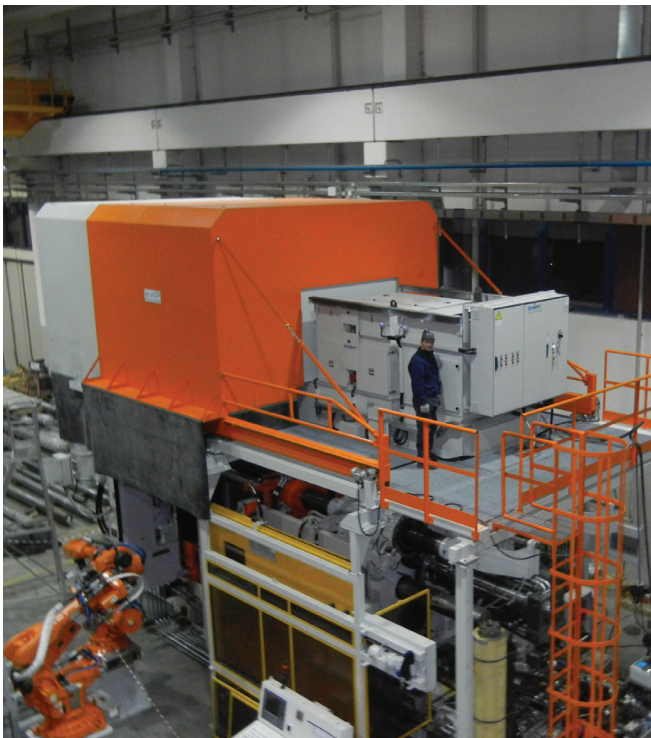

■ Hood into two parts complete with individual ENERPRESS suction and filtration system for recirculation of purified air in a die-casting machine - Russia



■ Hood on Hydra press connected to ENERPRESS centralized suction and filtration system - Italy



■ Hoods into two parts complete with individual ENERPRESS suction and filtration systems for recirculation of the purified air in the environment on IDRA OL4200S and OL2700S die casting machines - USA



■ Hoods into two parts on COLOSIO PFO die-casting machines of different tonnages connected to a centralized suction and filtration system ENERPROG - Russia



■ Hood into two parts complete with ENERPRESS filtration system, fan and individual expulsion into the atmosphere on ITALPRESSE IP1650 die-casting machine - Spain

Hoods and filters on diecasting machines



■ Hood into two parts complete with ENERPRESS suction and filtration system for recirculation of purified air in a COLOSIO PFO1000 die-casting machine - Czech Republic

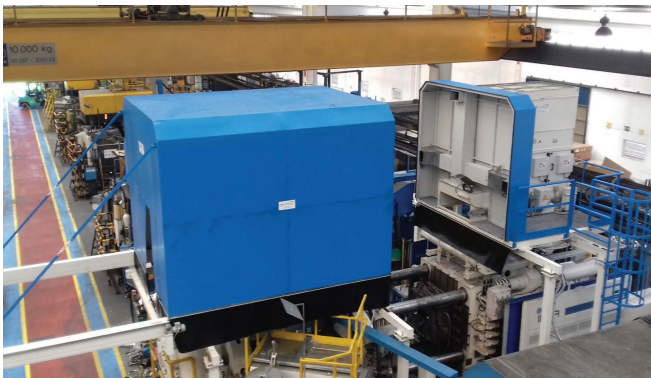

■ Hood into two parts on IDRA OL900S die-casting machine complete with individual ENERPRESS suction and filtration system, mobile hood on the injection side - Spain



■ Hood into two parts on FRECH DUALCAST 2700 die-casting machine connected to a centralized suction and filtration system ENERPROG



■ Hood into two parts complete with individual ENERPRESS filtration system, fan and individual chimney for the expulsion in the atmosphere of purified air on COLOSIO PFO560 die-casting machine - Spain



■ Hood into two parts complete with individual ENERPRESS suction and filtration system for recirculation of purified air in an environment on IDRA OL3700CS die-casting machines - Sweden



■ Hood into two parts complete with individual ENERPRESS suction and filtration system for recirculation of purified air in an environment on IDRA OL420S die-casting machine. Poland

Centralized implants



ENERPROG centralized suction and filtration system in 12 modules for a total suction flow of 200,000 m³/h dedicated to 22 presses - Italy



ENERPROG centralized intake and filtration system in 6 modules dedicated to 4 large tonnage presses - Iran



Centralized suction and filtration system ENERPROG - Italy



ENERPROG centralized suction and filtration system in 4 modules dedicated to 7 presses - Italy



ENERPROG centralized suction and filtration system in number 2 modules for a total sucked flow of 32,000 m³/h dedicated to 4 presses - Spain



ENERPROG centralized suction and filtration system in 10 modules for a total suctioned flow of 150,000 m³/h for 19 presses - Slovakia



Fume suction and filtering systems

Enercon has considerable experience in all the processes where suction and purification are combined with the temperature and humidity of the air.

Cascade filtering allows to cope with the most serious problems on a priority basis. Modular nature and technical compatibility of the systems, which we have been studying for years, enables us to put after and before the cooling and the filtering units, receivers, forced settling chambers, eddy-chamber and inertial multieddy-chambers.



■ *Technological systems for aspiration and filtration of fumes from melting furnaces and powders from mechanical processing at the service of aluminum refinery - Italy*

Enercon's flexibility enables the final user, in agreement with our technical department, to decide the customisation level of its system.

We also produce hoods for smelting furnaces that can keep their suction constant and present in every production stage. They are equipped with motorised systems and direct profile hoods with venture tubes. We also carry out modifications to existing plants.



■ Fume suction and filtration technology systems from melting furnaces complete with fume/water heat exchanger for aluminum foundry - Turkey

Suction and filtering systems for fumes from a large range of production processes:

- Smelting furnaces
(aluminium, brass, bronze, cast iron, steel);
- Shell casting;
- Sand-casting;
- Metal treatment and refinement.



■ Fume suction and filtration system (flow rate 20,000 m³/h) for aluminum smelting furnaces - Italy



■ 85,000 m³/h suction and filtration system for fumes treatment from aluminum melting furnaces - Slovakia



■ Extraction hoods on combustion opening of rotating aluminum smelting furnaces - Spain



■ Fume suction and filtration system from aluminum melting furnaces with chemical treatment of the fumes in the reactor and reagent storage and dosing system - Italy



■ Hoods on combustion openings and slagging doors for aluminum melting furnaces - Slovakia



■ Extraction hoods on gravity casting cells connected to a centralized suction and filtration system - Italy



■ Suction and filtration system for fumes from furnaces. Italy



Energy saving and recover

The recovery of energy contained in gases to be purified has allowed **Enercon** to face and solve the problem of "Energy Saving and Recovery".

Systems are fitted with heat recovery units that, by absorption water refrigerators, are able to supply heated or cold water to various offices and departments, thus reducing investment costs in a very short time.



■ Examples of fume/air heat exchangers installed on aspirations from melting furnaces upstream of the respective flue gas filtration systems complete with insertion of the heated air inside the production departments with high energy recovery.

Production consists of various kinds of boilers: from air to air, from air to water and from air to steam, manufactured with special stainless steel according to gas substances and temperatures.

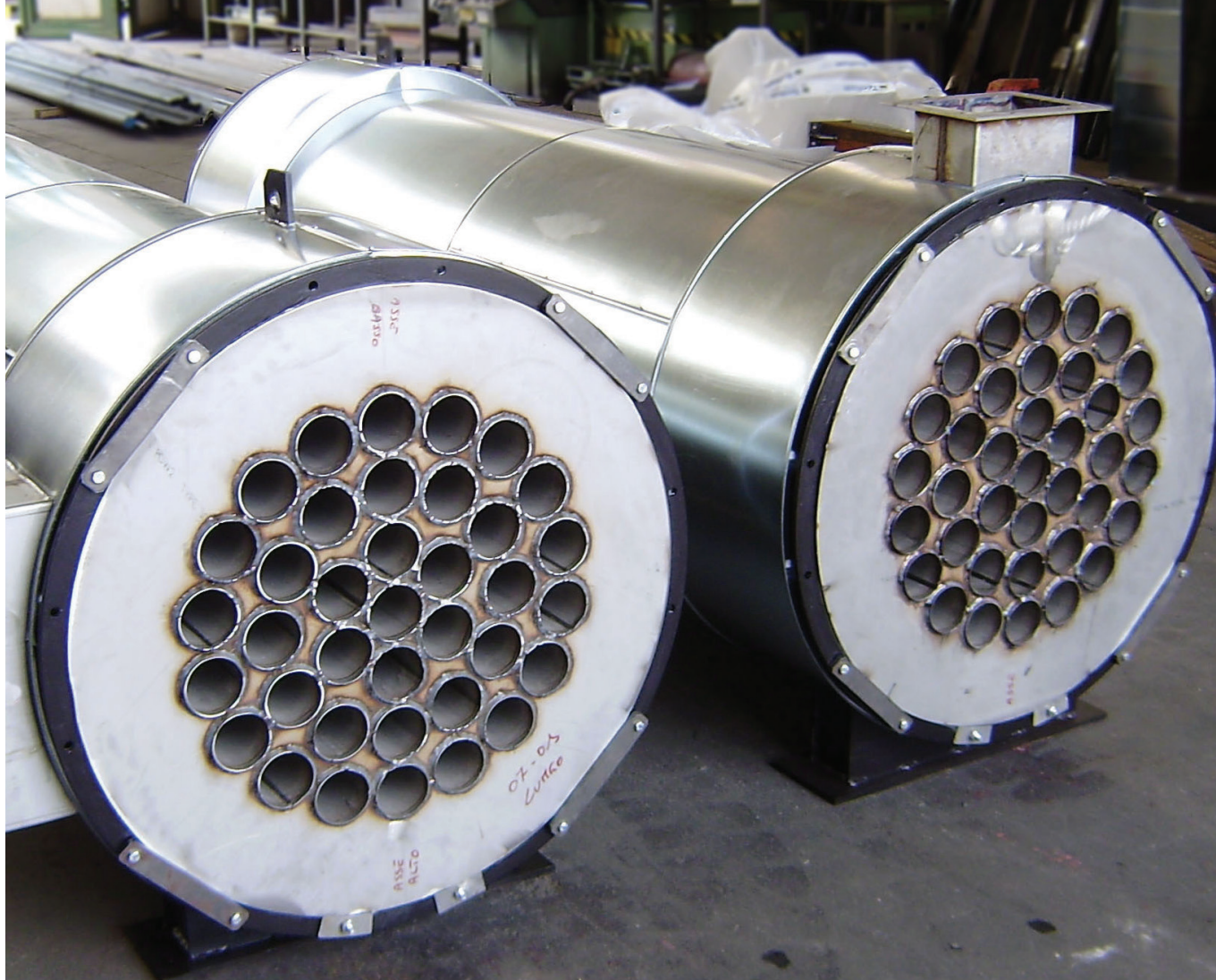

■ Tube bundle heat exchanger (fumes/air) for preheating combustion air before placing in the furnace - Italy

Energy saving and recovery:

- Fumes/air heat boilers;
- Fumes/water heat boilers.

The system is completed with dust filtering unit, adjustments and controls in conformity with the law.



■ Fume/water heat exchanger for the use of heated water inside the plant - Italy



Dust suction and filtering system



■ Suction and filtration system for bronze dusts - Italy

Enercon has reserved two types of particular technical treatment, while facing the topic of purification and suction of dusts coming from various productive processes: systems and environmental reclamation interventions.

The former takes into consideration the presence of an operator close to the polluting area, in this case **Enercon** will aim to safeguard the operator's respiratory system by means of personalized suction systems sending the polluting agent towards the filtering units.

The latter takes into consideration the use of the automatic production processes, with a limited presence of the operator near the working machines.

In this particular case **Enercon** will design and install particular customised interception hoods in order to avoid problems with the production process preferring, as an interception form, the non dispersion of the polluting agent in the air. The polluting agent will be sucked at its source and sent to the filtering units that, depending on the polluting agent to be treated, can be equipped with safety systems such as anti-deflagrating systems or fire detection and fire extinction systems.

In this way it is possible to have customised plants with high energy saving and considerable economic saving, at the moment of purchase and when in function.



■ Technological systems for suction, dust filtration and odor abatement from bronze shell casting machines and bronze melting furnaces - Italy

Abatement and suction systems of dust of various qualities and particle size with remote control:

- Grinding (aluminium, bronze, steel, etc);
- Steel moulding;
- Steel Heat treatment;
- Machine tools and work stations;
- Marble processing and polishing;
- Chipping;
- Oxygen cutting bench of all sizes;
- Cast iron processing;
- Core tightening.



■ Suction and filtration system from aluminum cutting powders -6.000 m³/h

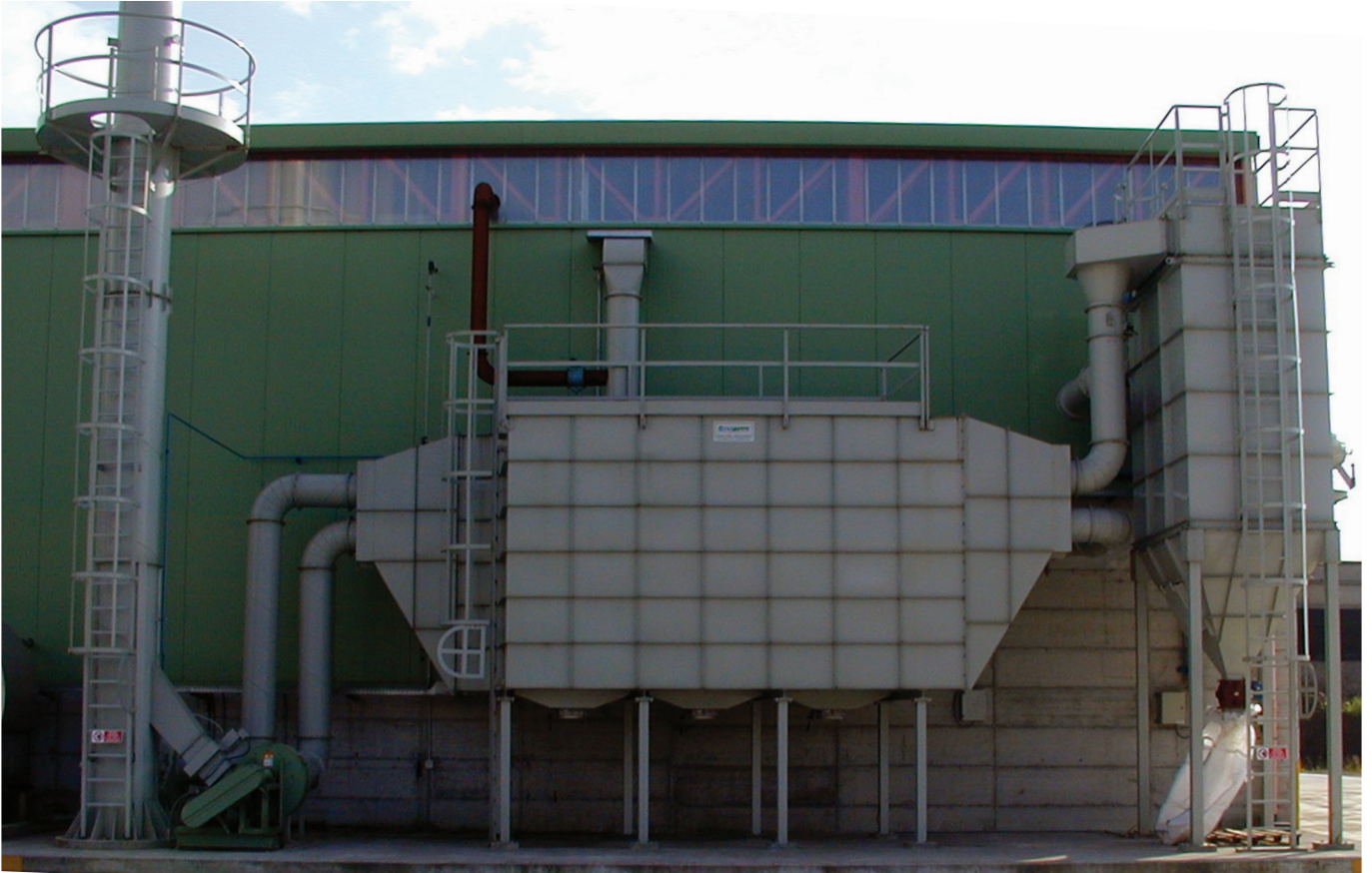

■ Suction and filtration system for dusts composed of a sleeve filter and a following active carbons filter - Italy



■ Dust extraction and filtration system for powders from mechanical processing - Italy



■ Suction and wet filtration plant from shot blasting operations - Slovakia



■ Suction and filtration system for dusts - Italy



■ Suction and filtration system for dusts - Spain



■ Suction and filtration system for dusts from grinding, flow rate 25,000 m³/h - Ukraine



Special applications

Thanks to the diversification of its activities and fields of intervention, **Enercon** is able to design and manufacture all the special plants required by its customers.

Our special applications belong to the equipment and systems that use those plant technologies that cannot be placed in a precise field.



Rotating and tilting ladle for transporting and pouring 800 kg aluminum - Italy

Enercon offers solid, valid assistance to the industrial operators in the field who have to deal with special or prototype production plant requirements and who need constructive technical support.



■ Automatic ladle wagon for the pouring of aluminum into holding furnaces at the service of die-casting machines - Spain

Enercon's fields of operation in the special applications field:

- Ladle car for feeding small holding furnaces;
- Foundry special equipment (cooling systems for die-cast parts);
- Special lifting and transport means (mobile cranes, overturning furnace loaders, etc.);
- Manufacturing and installation of sludge drying plant.



■ Soundproof cabin - Spain

Peripheral equipment for diecasting working cells



DEPOSIT MIX-C-V12

System for control and preparation of the release agent: precision control of mix and flow

This equipment has been designed to mix pure mould-release product and water according to the percentage established by the user.

The mixture is controlled by a water meter, which allows you to know the amount of incoming water, and by a dosing pump, which is managed by a programmable micro-controller and is used to provide the correct amount of pure product according to the percentage established.

With this system we obtain a very precise control of the mixing, alerting the machine with a signal

"error mixture" when the mixture is outside the set percentage.

A high resolution flow meter (up to 3 millilitres) is installed at the equipment outlet to control the product sent to the lubricator.

The equipment can be provided with up to 3 different mixture outlets, each with its manual shut-off valve. Moreover, a fourth outlet is available to collect product samples, if required:

This new version includes a variable speed drive (VSD) for the pump, which drives the product to the lubricator. This way, pressure is controlled constantly.

Operating at: FAGOR EDERLAN, FAGOR EDERLAN SLOVENSKO, LEAR CORPORATION MAGNESIO, JINJIANG ALFISA, INDUSTRIAL VILASSARENCA, COPRECI

JET COOLING

The final solution to your glued mould and workpiece micro-porosity problems

CORE COOLING has been designed to cool hot points, cores, and inserts in all die casting moulds. This equipment is used to remove glued parts, during extraction, as well as pores and micro-pores resulting from the high temperature reached by some mould parts during the injection process. This is why CORE COOLING makes a certain amount (determined during a specific time interval) of water and air flow, at a pressure ranging between 0 and 20 bar, through one or more circuits connected to one or more hot points of the mould.

The whole cycle consists of three phases:

PHASE 1: the equipment injects pressurised water into the cooling circuit of the hot points, during a programmed time, checking the flow, according to the maximum/minimum tolerance percentage, and any possible obstruction in the cooling circuits.

PHASE 2: once the cooling time has elapsed, the circuits are dried with pressurised air injected for a programmed amount of time. This way, the next metal injection cycle can be performed under the utmost safety conditions.



PHASE 3: this last phase checks the tightness in order to re-inject the air into the circuits, this time with the outlet closed, to detect any loss of pressure. A metre allows you to store and display the flow log, consisting of the last 100 cycles, as well as the total amount of water consumed. This way, you can check the resins in the water inlet filter and prevent the circuit from calcifying.

Operating at: FAGOR EDERLAN, NEMAK SPAIN, FIASA, CIE VILANOVA, EDERTEK, MARTINREA HONSEL SPAIN, SANDHAR TECHNOLOGIES BCN, CIE AUTOCOM (BRASIL), CIE MATRICON (RUMANIA), MONFORT, SEAT



Assistance and maintenance services

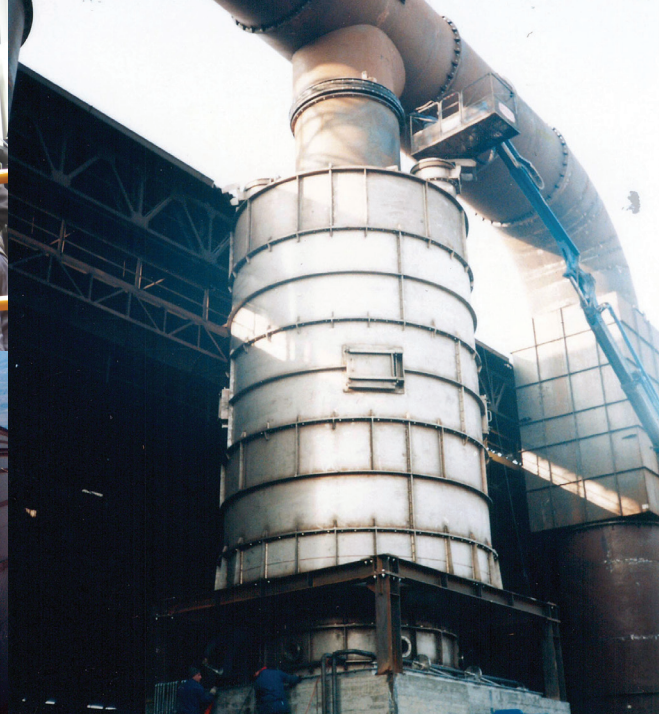

Our aim is to offer complete customer care in the field of industrial systems in general, and in the various other fields in which we operate. **Enercon** puts at the customers' disposal skilled workforce for the installation, assistance and maintenance of the new plants as well as for the adjustment and restoration of the existing plants and, in any case, for all operations requiring the intervention of skilled and specialised personnel.

Enercon offers itself as a company that, thanks to its dynamicity, flexibility and diversified experience is able to satisfy different systems' needs and problems ensuring excellent results in the problem solving, also with annual contracts.

Enercon and its offices are at your disposal for a profitable cooperation and for any further explanation.

Applications:

- Technical Assistance for hydraulic, suction, pneumatic and oleodynamic plants (also by other suppliers);
- Contracts for programmed maintenance;
- Extraordinary maintenance;
- Industrial carpentry;
- Plant Reparation and Adjustment;
- Control of fire detection and extinction systems.



Via Fornasina, 60 - 25080 Muscoline (BS) - Italia

Tel.: +39 0365.373193 - Fax: +39 0365.373186

info@enercon.it